



Feature Benefits

1080p Video

The ntouch® VP2 sets a new standard in video quality for video calls with up to 1080p resolution. Because it is created specifically for the Deaf community, the ntouch VP2 optimizes the video for ASL communication.

Multi-Color LightRing

Sorenson's familiar and distinctive LightRing™ is even better on the ntouch VP2. The LightRing is three times brighter and offers eight customizable color choices so that you can better see and identify incoming calls before you answer.

Group Call

With the Group Call feature, you can talk to up to four other SVRS® customers at once.

Call Transfer

Call Transfer lets you transfer a call from one ntouch device to another.

Wi-Fi Internet Connectivity

The ntouch VP2 supports Wi-Fi connections to your Internet router, making the placement of your videophone more flexible.

Screensaver Options

The ntouch VP2 offers you multiple choices of animated Screensavers to let you customize the image displayed on your TV screen when you're not using the videophone. You also get to choose the time delay before the screensaver appears.

Sorenson myPhone

Sorenson myPhone lets you have one phone number for all your ntouch devices and syncs your devices' Contacts, Favorites, Call History, and SignMail® records.

Bluetooth Device Support

ntouch VP2 supports the use of wireless Bluetooth keyboards. This feature makes it easier to share text while in a call.

Add Call

When on a call, you can put the current call on hold to make a new call. You are able to easily switch between the two calls.

HDMI Pass-Through

The HDMI Pass-Through feature lets ntouch VP2 connect cable TV/satellite boxes, DVD/BD players or streaming devices to a TV display using the one HDMI-In port connected to the videophone. You can then use the ntouch VP2 remote control to easily switch between the ntouch VP2's image and the image coming from the external connected device.

Hide My Caller ID

Remain anonymous by hiding your Caller ID* phone number from being sent to others when calling.

*Caller ID can't be hidden when calling certain numbers, such as 800 numbers and 911.

Don't Accept Anonymous Calls

Block calls from anonymous callers, even those who have hidden their Caller ID.

Contact Photos

Contact Photos lets you create your own SVRS profile photo to show in the Contacts List of your friends, family and colleagues.

Personal SignMail Greeting

Personal SignMail® Greeting lets you set up your own unique SignMail greeting video.

Share Text/Contact

For those times when it is important to use words to be clear, the Share feature uses real-time text to send information to the caller or the interpreter. If you don't have a keyboard, you can use an on-screen keyboard.

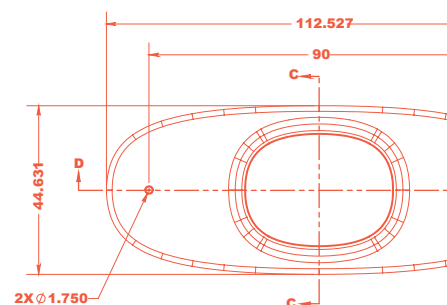

Quick-Call Button

The buttons on the top of the ntouch® VP2 Main Unit let you quickly make a call from your Favorites, Call History or Contacts Lists without using the remote control. You can even use the buttons to quickly call Sorenson Customer Service or Technical Support.

Corporate Directory

The Corporate Directory feature lets ntouch VP2 connect with LDAP directories commonly used in businesses, schools, and other agencies. Whenever your LDAP directory is updated, the videophones are automatically updated as well.

Video Center

Sorenson's Video Center offers special programming created specifically for Deaf audiences and available only to SVRS customers.

Tunneling

Some networks are so restrictive they do not allow videophones to work without modifications. If a network won't allow videophones to work, the Tunneling feature may provide a way to connect your calls.

myRumble®

myRumble allows you to quickly identify who is calling by assigning specific vibration patterns to different contacts when receiving calls on your mobile phone.

Voice Carry Over (VCO)

ntouch VP2's Voice Carry Over (VCO) calling feature gives you the option to make either 1-Line or 2-Line VCO calls. ntouch VP2 has two built-in microphones to provide improved audio quality for your 1-Line VCO calls.

Call Waiting

While on a call, receive notifications of another incoming call with Call Waiting. If you take the call, it's easy to switch between the two calls.

SignMail

When you can't answer a call, SignMail® lets callers record a video message that you can watch later.

Spanish VRS Contacts

The Spanish Contacts feature lets you identify people in your Phonebook as Spanish Contacts. When you call these contacts, you will automatically be routed through SVRS® Español, making the calling process faster and more efficient.

New VRS Call

ntouch VP2's New VRS Call feature lets you start another VRS call while staying connected to the same interpreter. When your call with a hearing person ends you don't hang up, you just dial the new call yourself.

N11 Dialing

Access all the N11 numbers available in your local area. By dialing 611, you will be connected directly with Sorenson Customer Service. N11 numbers include: 211, 311, 411, 511, 611, 711, 811 and 911.

Number Search

You can use your ntouch apps to search for phone numbers of nearby businesses and then directly dial the business.

Push Notifications

The ntouch apps for iOS and Android can now use these devices' native user interface for incoming calls, and will receive calls even when the app is not running.